

244LD *LevelStar* Intelligent Buoyancy Transmitter for Level, Interface and Density with Torque Tube and displacer – HART and Foundation Fieldbus –

Vers. 6.2.x



The intelligent transmitter 244LD *LevelStar* is designed to perform continuous measurements for liquid level, interface or density of liquids in the process of all industrial applications. The measurement is based on the proven Archimedes buoyancy principle and thus extremely robust and durable. Measuring values can be transferred analog and digital. Digital communication facilitates complete operation and configuration via PC or control system. Despite extreme temperatures, high process pressure and corrosive liquids, the 244LD measures with consistent reliability and high precision. It is approved for installations in contact with explosive atmospheres. The 244LD combines the abundant experience of FOXBORO with most advanced digital technology.

FEATURES

- HART Communication, 4 to 20 mA, or Foundation Fieldbus
- Configuration via FDT-DTM
- Multilingual full text graphic LCD
- IR communication as a standard
- Easy adaptation to the measuring point without calibration at the workshop
- Linear or customized characteristic
- 32 point linearisation for volumetric measurement
- Backdocumentation of measuring point
- Continuous self-diagnostics, Status and diagnostic messages
- Configurable safety value
- Local display in %, mA or physical units
- Process temperature from $-196\text{ }^{\circ}\text{C}$ to $+500\text{ }^{\circ}\text{C}$
- Materials for use with aggressive media
- Micro sintermetal sensor technology

Repair and maintenance must be carried out by qualified personnel!

Life Is On

Foxboro[™]
by Schneider Electric

CONTENTS

CHP. CONTENTS	PAGE	CHP. CONTENTS	PAGE
1 DESIGN	3	6 COMMISSIONING	9
2 METHOD OF OPERATION	3	7 DECOMMISSIONING	9
3 IDENTIFICATION Nameplates	4	8 CALIBRATION OF TRANSMITTER Local keys Menus on the LCD	9 10 11
4 MOUNTING	5	9 DIMENSIONING OF DISPLACER	16
4.1 High medium temperatures	5	10 MEASURING PRINCIPLE	18
4.2 Mounting on top of the vessel	5	10.1 Block diagram with HART communication	19
4.3 Mounting on the side of the vessel	5	10.2 Explanations to Block diagrams	19
4.4 Mounting the wafer body	6	11 SUPPLY OF TRANSMITTER	22
4.5 Displacer 204DE	7	12 Error messages on LCD and on DTM screen	24
5 ELECTRICAL CONNECTION	8		
5.1 Signal wire connection	8		
5.2 Ground	8		

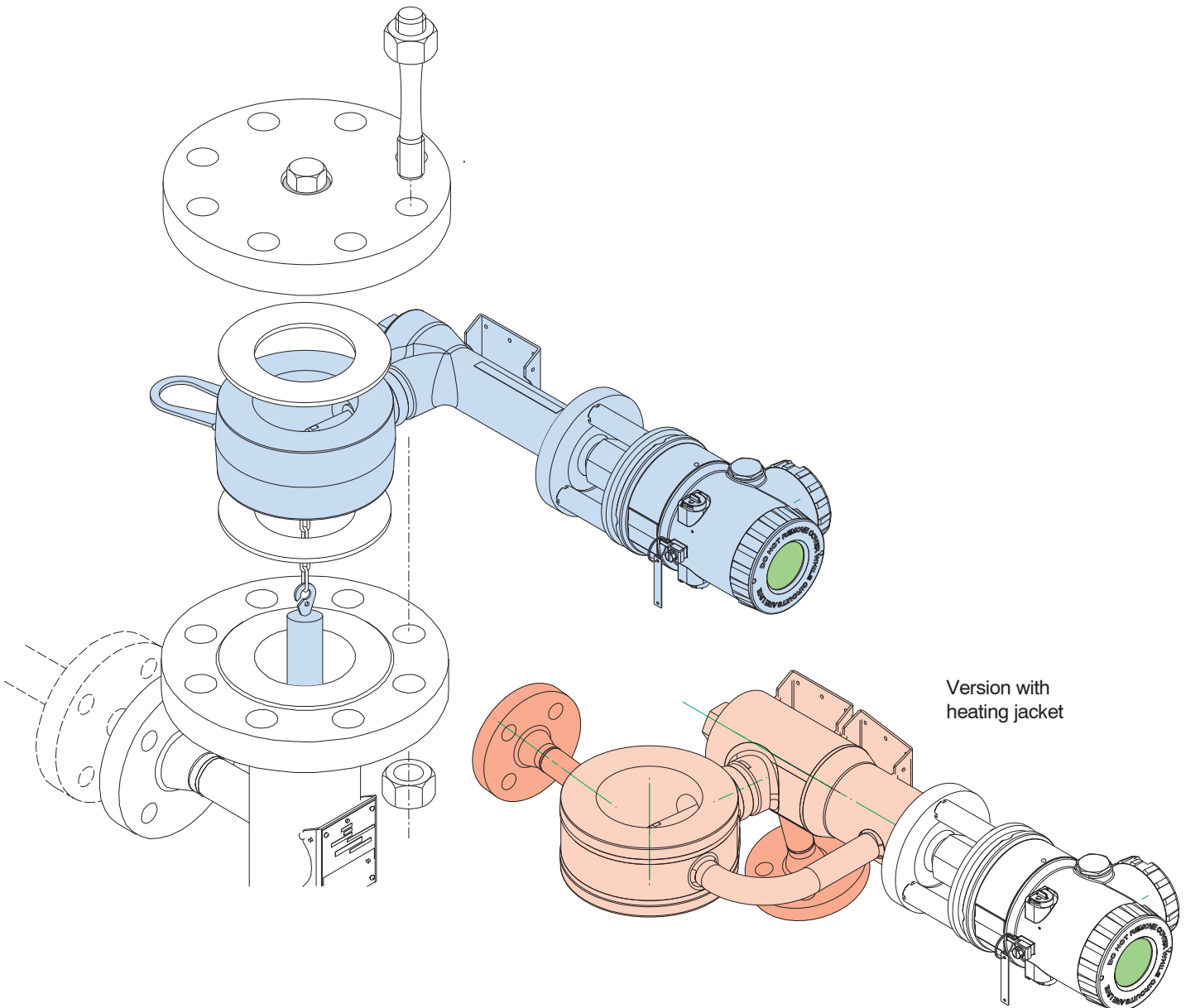

1 DESIGN

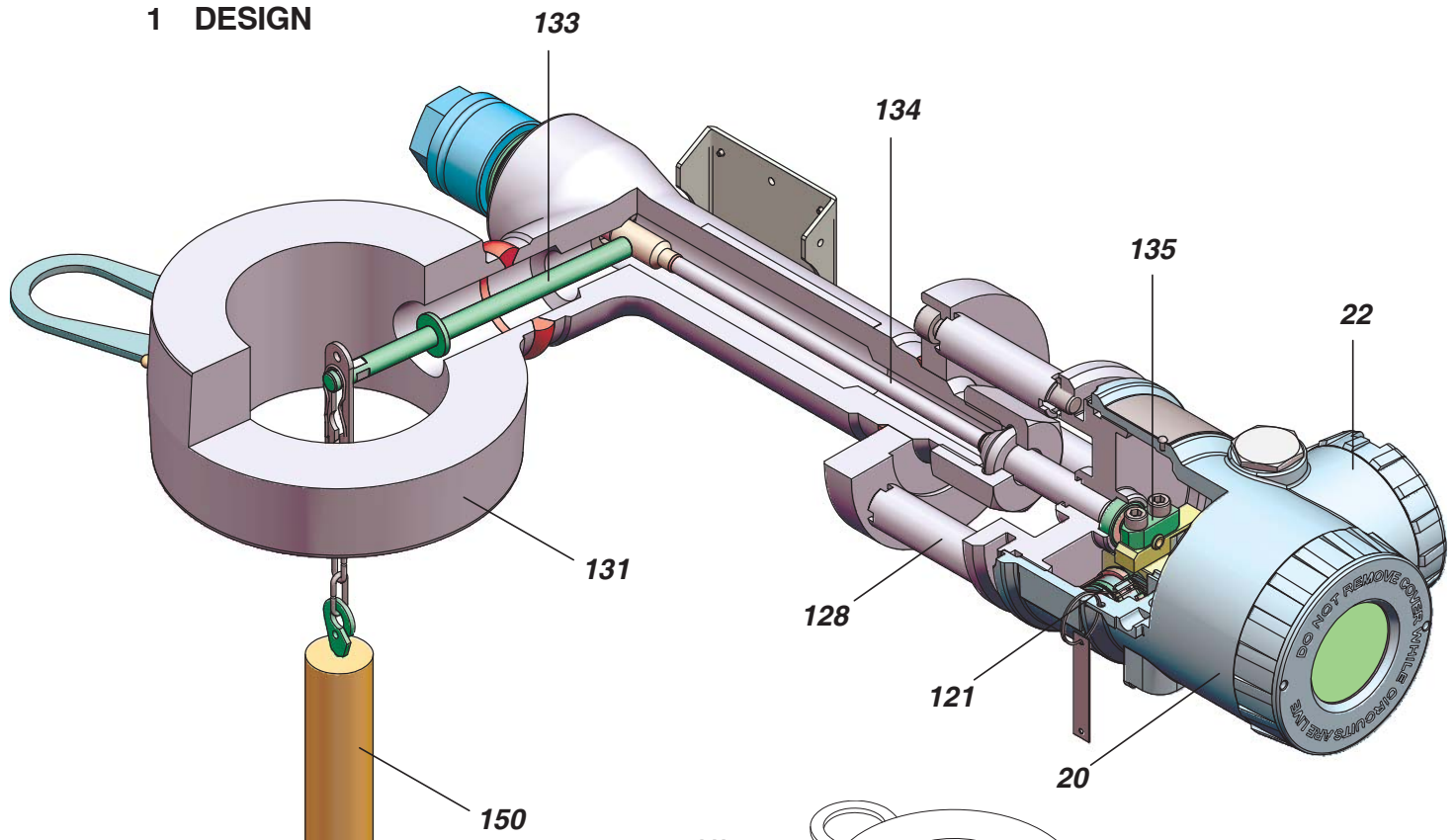

- 20** Amplifier
- 22** Terminal compartment
- 121** Sensor
- 128** Heat sink
- 131** Wafer body with torque tube
- 133** Transmission lever
- 134** Torque tube
- 135** Clamping lever
- 150** Displacer with suspension chain
- LH** Version for left-hand mounting

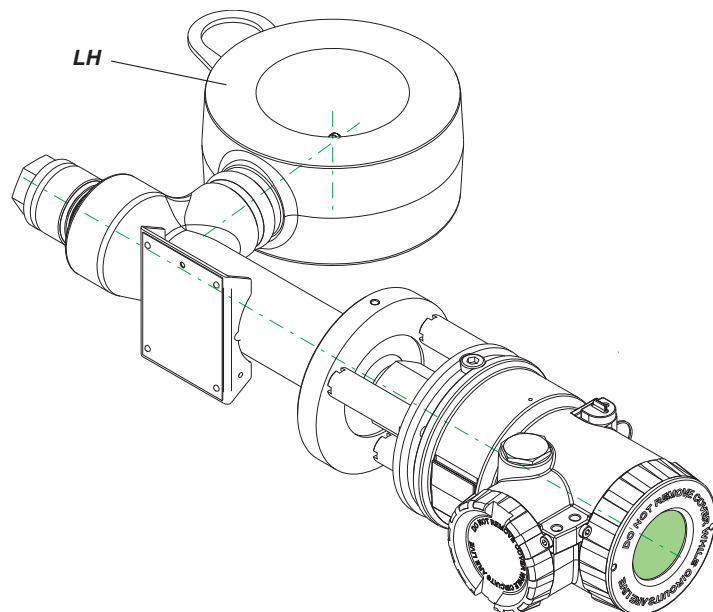

For left-sided mounting all inside parts are arranged in inversed manner.

2 METHOD OF OPERATION

The buoyancy force of the displacer **150** is transferred via transmission lever **133** and torque tube **134** to operating rod of the sensor, where it acts on free end of sensor element **121**.

Four thin film metal strain gauge elements are sputtered onto sensor element, which change their resistance in the ratio of the tensile or pressure tension. These four thin film metal strain gauge elements are connected as a Wheatstone full bridge supplied from amplifier.

The voltage at the diagonal bridge section which is proportional to the effective weight is fed to the electronic amplifier as an input signal.

This voltage is converted via the electronic amplifier into the 4 to 20 mA or digital two-wire output signal.

The amplifier is supplied by the signal current circuit in two-wire mode.

3 IDENTIFICATION

The transmitter is identified with several labels.

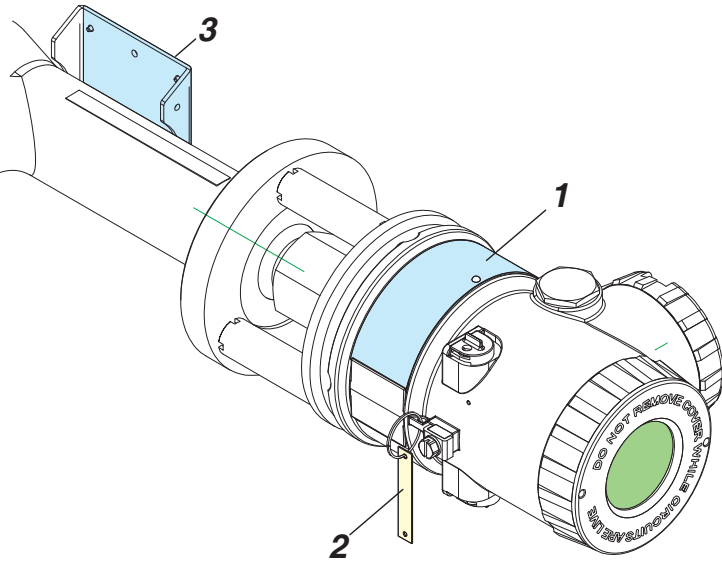

Transmitter nameplate 1

The transmitter nameplate shows the Model Code of transmitter, the serial No. and certification data. (Example)

LEVEL - MESSUMFORMER /-TRANSMITTER		FOXBORO	Made in Germany by	CE
MODEL		ECKARDT	FOXBORO ECKARDT GmbH	0102
SER.No.			D - 70376	
ECEP	REV.Nr.			
VERSTÄRKER / AMPLIFIER		AUFNEHMER / SENSOR		
KOMMUNIKATION		Werte siehe Betriebsanleitung / Data see Instruction manual		
PTB Nr.	ATEX	TYPE	PTB Nr.	ATEX

ECEP: ID No. for special version

Tag No. label 2

(Example)
Attached to amplifier.

LID 09/16

Optional label with devices acc. to NACE-Standard. With attached Tag No. label, on the rear side of Tag No. label.

Boiler label 3

Boiler label with nominal pressure, material, permissible pressure and temperature load, serial no., etc

GEHÄUSE VON ARMATUREN		
BODY OF TRANSMITTER		
BAUJAHR / YEAR		CE 0036
INHALT / VOLUME LI		
SER. Nr.		
WERKSTOFF / MATERIAL		
PN		
PRÜFDRUCK / TEST PRESSURE		bar
ZUL. UEBERDRUECKE IN ABHAENGIKKEIT D. TEMPERATUR		
PERMISSIBLE PRESSURE-TEMPERATURE RATINGS		
SURPRESSION ADMISSIBLE		
*C		
bar		
<small> <math>T < 10^{\circ}C</math> BE TR. TEMP. SCHRAUBEN AUS A2/A4 VERWENDEN USE SCREWS MADE FROM A2/A4 WHEN OPERATING TEMPERATURE IS <math>T < 10^{\circ}C</math> </small>		
Made in Germany by FOXBORO - ECKARDT GmbH D-70376 STUTTGART		

Adjustment data label

Matching the displacer:
Take care of correct matching of transmitter and displacer while mounting. Each transmitter is calibrated to the respective displacer according to the ordering data in the factory. Each transmitter/displacer pair has adjustment data labels to prevent dismatching.

Torque tube material label

MATERIAL TORSIONSROHR - TORQUE TUBE 1.4404 / 1.4435 / 2.4610 / 2.4816

Refers to the material of the torque tube and is attached at the edge of the flange.

Thread label

In the version with NPT threads, near the cable gland is a label describing the type of thread.

4 MOUNTING

The 244LD *LevelStar* is directly built onto the vessel or alternatively on a side-mounted displacer chamber (e.g. 204DC).

During installation, the permissible static pressure and the ambient temperature range must be observed. (see chap. 3, Boiler label).

4.1 High medium temperatures

It is important to ensure that the max. permissible temperature of the electronics housing of 85 °C and that of the sensor housing of 120 °C is not exceeded.

For explosion-proof equipment and devices approved for overfill protection according to WHG, the information in the product specifications PSS EML0710 and in the certificates or approvals must be observed.

4.2 Mounting on top of the vessel

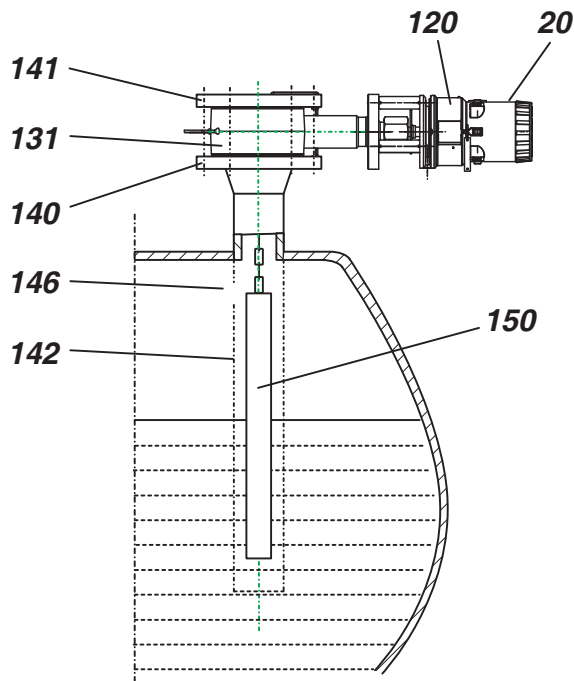

- | | |
|------------------------------|---------------------------------|
| 20 Amplifier | 141 Blind flange |
| 120 Sensor housing | 142 Protection cage/tube |
| 131 Wafer body | 146 Venting hole |
| 140 Connecting flange | 150 Displacer 204DE |

If the vessel contains a turbulent liquid a protection cage / tube should be used. It has a venting hole **146** above the maximum liquid level. Between the protection cage / tube **142** and the displacer **150** must be a gap of 5 ... 10 mm.

4.3 Mounting on the side of the vessel

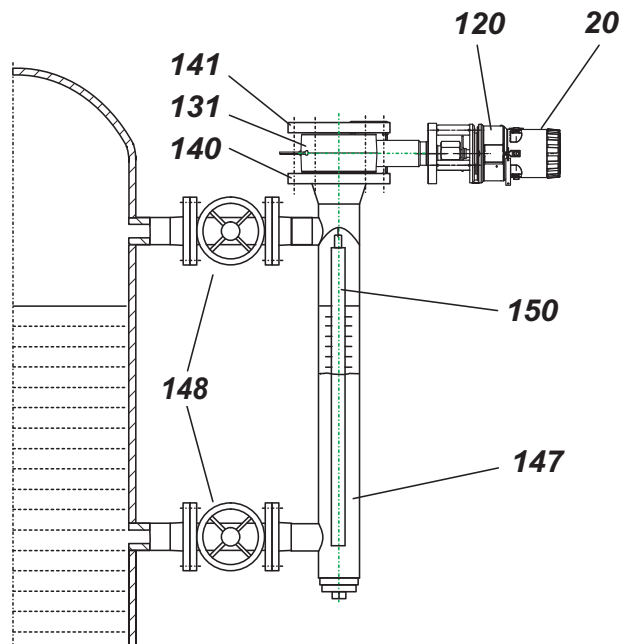

- 147** Displacer chamber 204DC
148 Shut-off device

When used in Zone 0, fittings resistant to flame penetration must be used.

If the chamber has not already been mounted by the customer, it must be mounted on the vessel with suitable bolts and seals (not included in the scope of delivery). Be sure that the displacer chamber is exactly vertical.

Between the protection cage or tube and the displacer must be a gap of 5 ... 10 mm.

4.4 Mounting the wafer body

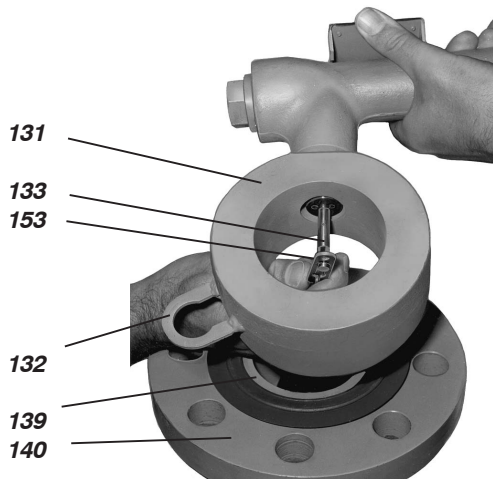

Place the seal **139**¹⁾ on the connecting flange **140**. Insert displacer in displacer chamber or vessel. Hold 244LD *LevelStar* **131** above connecting flange. Engage eyelet **153** of displacer chain in notch in transmission lever **133** and fit wafer body onto connecting flange.

Do not drop the appended displacer!

Avoid jerky load!

Set 244LD *Level Star* to the mounting flange:

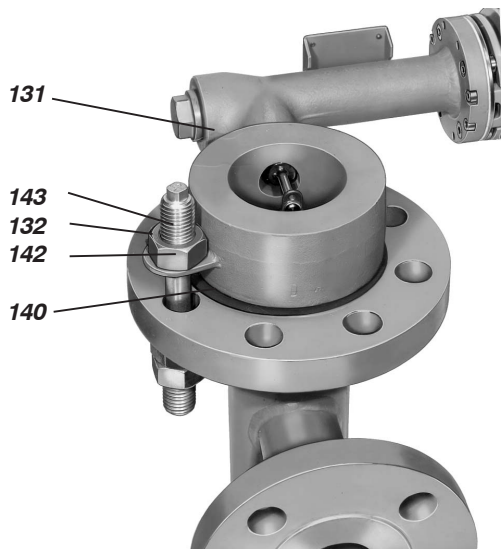

In order to make mounting easier, mounting bracket **132** is secured with a stud **142** to connecting flange **140**. It is advisable to preassemble a stud by screwing a nut **143** onto thread.

Insert this stud through the top of mounting bracket and connecting flange. Screw sufficient number of nuts onto thread and reduced shaft from underneath for the wafer body to be firmly in position.

Place seal **139**¹⁾ on wafer body. Place blind flange **141** on wafer body so that holes in blind flange and connecting flange **140** are aligned.

Insert remaining studs. Screw on nuts and tighten gently. Unscrew nut **143** and pull stud downwards.

Tighten the nuts on all bolts with the appropriate wrench. Proceed crosswise to avoid jamming.

Recommended tightening torque (Prestressed to 70% of minimum yield point at 20 °C)							
Mat.	M12	M16	M20	M24	M27	M30	M36
A2-70	40 Nm	95 Nm	185 Nm	310 Nm	450 Nm	630 Nm	1080 Nm
1.7225 1.7709 (8.8)	50 Nm	120 Nm	250 Nm	435 Nm	630 Nm	860 Nm	1500 Nm

Note:

Studs and nuts material depends on material of wafer body and temperature of process medium.

Note for displacers with diameters less than 30 mm

Displacers with diameters < 30 mm can also be suspended when the wafer body has already been mounted.

As an aid to installation, a wire can be pulled through the hole in the eyelet **153**. The displacer is lowered through the wafer body with this wire, past the transmission lever and into the displacer chamber or vessel. The eyelet must then be hooked onto the notch **133** in the transmission lever.

Finally remove the wire.

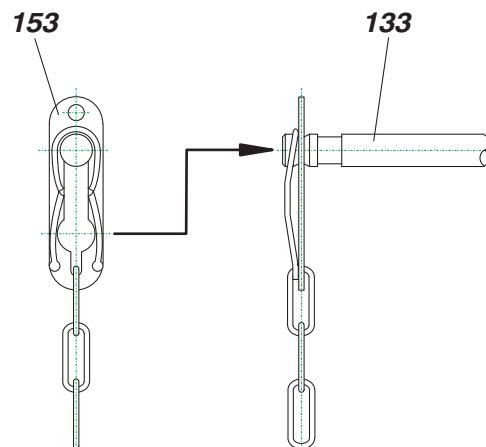

1) When using an electrically non-conducting soft gasketing, the wafer body must be grounded, see chap. 5.2 .

4.5 Displacer 204DE

Ensure correct matching of transmitter and displacer while mounting. Each transmitter is calibrated to the respective displacer according to ordering data in the factory. See also chap. 3 "Adjustment data label".

Replacing displacer

Enter the changed data of displacer on the adjustment label (see chapter 3).

Pressure Rating

The displacer must be designed for the pressure rating of the vessel - however, at least to the operating pressure - and ordered accordingly. Here the maximum possible temperature must be taken into consideration.

Displacers made of PTFE are made from solid material, and are, therefore, suitable for all pressures.

Divided displacers

Displacers with a length of more than 3 m (1 m with PTFE) are divided. The displacer elements are screwed together and secured with the wire clip **151** to avoid bending or damage during insertion into the vessel. The elements of displacers with $\varnothing < 13$ mm are not screwed together; they are secured with hook and eyelet **152**. Additional securing is not necessary ¹⁾.

Lengths < 350 mm or > 3000 mm, and density ranges < 100 kg/m³ or > 2000 kg/m³ on request.

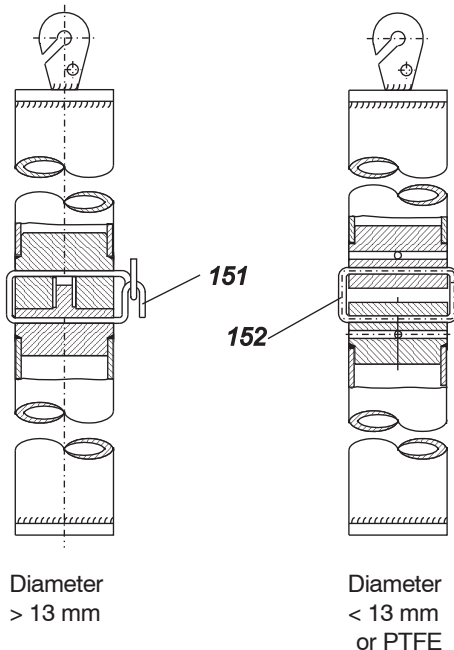

Damping element

In operating conditions with strong external vibrations - e.g. nearby compressor stations - the damping element (Option -D) should be used.

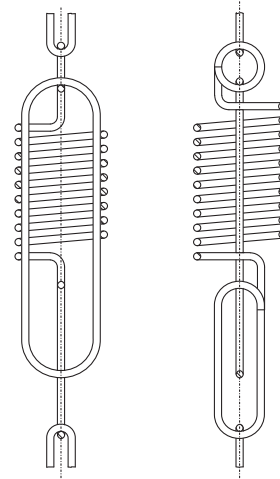

It is hooked onto the suspension chain of the displacer in place of 7 chain links (105 mm). This spring is specially matched to the resonance frequency of the displacer and is made of stainless steel 1.4310 (operating temperature up to 250 °C) or Hastelloy C (operating temperature up to 350 °C).

Use in Zone 0 or as Overfill Protection according to WHG ²⁾

Mechanics

When used in Zone 0, displacers must be secured against oscillating when

- displacer made of metal, explosion group IIC
 - displacer made of metal, explosion group IIB/A, length > 3 m
 - displacer made of PTFE+25% carbon, IIC/B/A, length > 3 m
- The displacer is to be attached in such a way that it is not in the main filling jet stream.

When used as overfill protection according to WHG, the displacer must always be installed with guidance.

Guidance devices over 3 m long must also be secured against bending.

Potential equalization

When used in Zone 0, only displacers of metal or PTFE +25 % carbon may be used.

A potential equalization line must be mounted as an electrical bypass of the displacer suspension(s) if the residual displacer weight is < 10 N, or if more than 6 contact points are present.

To avoid the danger of electrostatic ignition, a connection to the transmitter with good conductivity must be ensured.

The volume resistance between the lower end of the displacer and ground may not exceed 1 M Ω .

1) When used in Zone 0, the eyelets must also be welded.

2) Please see corresponding certificates for further details

5 ELECTRICAL CONNECTION

5.1 Signal wire connection

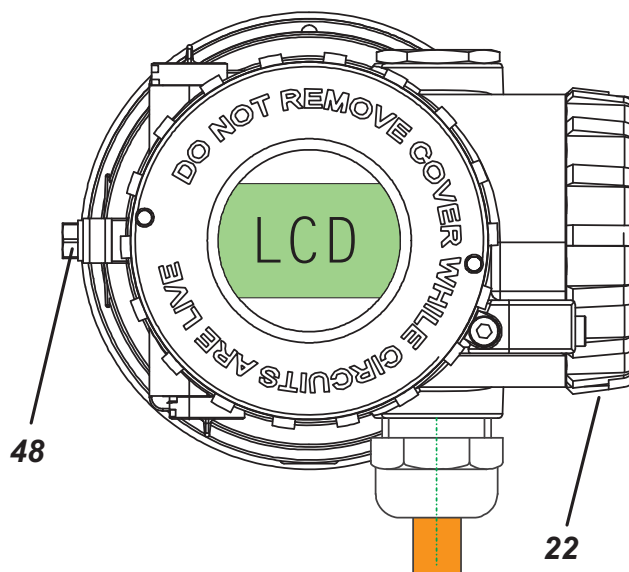
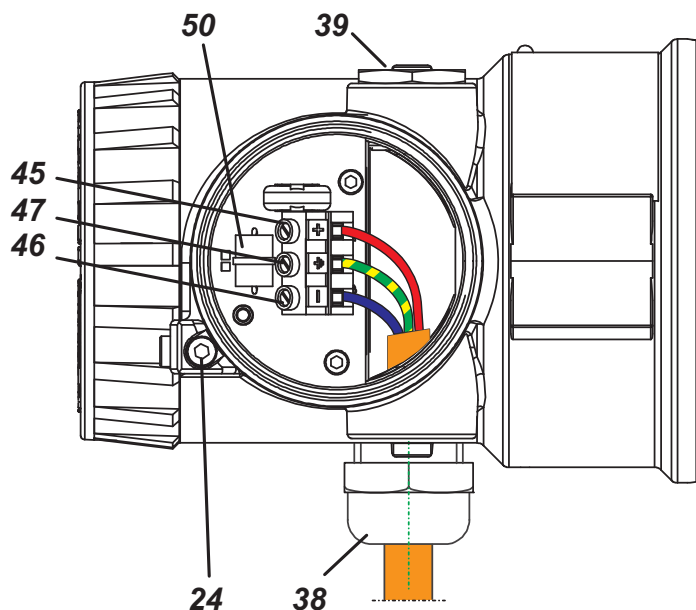

Guide **cable** through cable gland **38** from the bottom; observe especially the shielding.

Check before mounting cable glands if threads are matching, otherwise housing can be damaged. Cable gland **38** and cover screw **39** are interchangeable.

Connect **input signal** to terminals **45 (+)** and **46 (-)** . The screw terminals are suitable for wire cross sections of 0.3 to 2.5 mm².

For selection of the cable see also the recommendation for cable types acc. to IEC 1158-2.

Transmitters supplied without cable gland, the cable gland used has to conform to possible Ex requirements. This is the user's responsibility.

Note:

For explosion-proof devices follow reference for cable gland and cover screw in document "Safety Instructions 140 Series"

- 22** Connecting compartment cover
- 24** Cover lock
- 38** Cable gland
(permitted cable diameter 6 to 12 mm)
- 39** Cover screw
- 45** Connection terminal "+" wire cross section
- 46** Connection terminal "-" section
- 47** Ground terminal max. 2.5 mm²
- Test sockets (Ø 2 mm) integrated in terminal block
- 48** External ground terminal
- 50** Overvoltage protection (if present)

Actions:

- Loosen cover lock **24** (if provided) and unscrew cover **22** .
- Guide cable through cable gland and connect to terminals **45, 46** and **47** .
- If necessary connect external ground terminal **48** .
- Screw cover **22** and install cover lock **24** (if provided).

5.2 Ground

If connection to ground is necessary (e.g. potential equalization, protection of electromagnetic influence), ground terminal **47** or external ground terminal **48** must be connected.

When using an electrically non-conducting gasketing, the wafer body must be grounded by wire **E** with the connection flange.

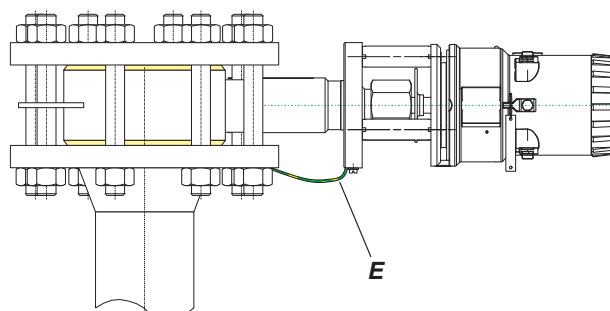

6 COMMISSIONING

In any case, installation and safety regulations have to be checked prior to commissioning. See document EX EML 0010 A: “**Safety Operating Instructions**”

After correct installation and connection to power supply unit, the transmitter is ready for operation:

$U > 12 \text{ V dc}$ (HART)

If necessary the configuration of lower range value, upper range value and damping has to be checked.

With HART an ampmeter can be attached into the output current loop for check.

7 DECOMMISSIONING

Prior to decommissioning take precautions to avoid disturbances:

- Observe Ex. protection.
- Switch off power supply.
- Caution with hazardous process media!
With toxic or harmful process media, observe relevant safety regulations.

Before dismantling the transmitter, the procedure below should be followed:

- Depressurize vessel or displacer chamber.
- Drain off measuring medium in displacer chamber.
- Protect the environment; do not allow measuring substance to escape. Catch and dispose them properly.

The procedure for dismantling the transmitter is the reverse of that described for mounting.

8 SETTING OF TRANSMITTER

Zero, lower range value, upper range value and damping of the transmitter are set by manufacturer as specified in the order:

- Dimensions of displacer: Length, density, weight
- Setting Lower Range Value by weight F_0 :
without Zero elevation = 0;
with Zero elevation = Value of elevation
- Upper Range Value corresponding to buoyancy force of displacer (see Chap.9)
- Output Range and unit

Therefore, calibration at start-up is not necessary.

Operating data and displacer data are stored in the transmitter according to the order.

Configuration becomes necessary if this data deviates from the stored values.

In case the order does not include this data, the transmitter is supplied as follows:

displacer weight	=	1.500 kg
buoyancy force	=	5.884 N (0.600 kg)
indication	=	0 ...100 %
damping	=	8 sec (90 % time)

Setting via HART Protocol

- Setting with PC and FDT-DTM
- Setting with Handterminal

Setting via operating push buttons

Setting can be done by means of the push buttons at the transmitter, see next page.

"Warm-up" prior calibration and zero point corrections

During final assembly at the manufacturer, **ZeroBasic** is adjusted. For this, the displacer data are entered from which the 244LD automatically calculates the zero point in "Auto Range" mode.

It is recommended that the customer perform the **ZeroCorrect** function at commissioning. In this case, the transmitter is brought up to operation temperature ("hot Adjustment") and subsequently the zero point. So the measurement error for the process temperatures (either very high or very low) is kept small. Inaccuracies during installation are taken into account. The function can be performed by the DTM or locally on the LCD and push buttons (see page 12, Menu 4 PV offset).

If required, it may be necessary to activate or deactivate a zero point correction. For this, the **SpecialZero** function is provided. It is used to compensate a zero shift as a result of the influence of high or low medium temperature (e.g., during the start of the process).

This function is only accessible via the DTM.

For details about the DTM, please follow the instructions on the screen.

Starting operation

After starting (after power-on) the Foxboro logo is briefly displayed,

then **Device Info ...**

244LD LevelTransmitter V 0.45.1158 H	Device Type
	Measuring task
	Version

... and then the **operational view:**

<div style="font-size: 2em; font-weight: bold;">7.099</div> <div style="font-size: 0.8em;">m3 [] A</div>	Measured value
[]	Status line
[]	Status line: padlock = protected
[]	A Autorange mode
[]	M Manual mode
[]	Measured value in bar chart
m3	physical unit, or %

The operational view is the display in normal operation.

Manually or Autorange?

When ordering, the customer has stated range and the density of the measuring medium (or the densities of the media). From these informations the real displacer was manufactured.

On delivery the mode is set to Autorange: The displacer data (diameter, length, weight) and the density of the media were stored before delivery via FDT / DTM in the 244LD LevelStar. From this data, PV-offset and Upper Range Value URV are calculated automatically, which allows an immediate operation without any additional calibration in the field.

However, if the manual method is preferred, so the values can be entered manually.

In Manual mode the classic method is possible to take over the respective values of the buoyancy forces with the operating conditions for 0 % (with level: empty vessel) and 100 % (with level: full vessel).

Important NOTE:

On the following pages, the operation of the transmitter will be described with local keys.

For the setting of all values and special functions we strongly recommend the use of the FDT DTM technology.

This requires only a PC (notebook), a modem and the FDT software that you can download from our web page free of charge..

The operation is much simpler and more convenient using FDT DTM technology and, additional, more features are available. If you use local keys, not all features are accessible.

Setting via local keys and LCD

The operating parameters and settings can be viewed on site and in some cases changed.

For local operation a full graphic LCD is available and 2 buttons on the outside of housing.

Inside the unit there are no other controls.

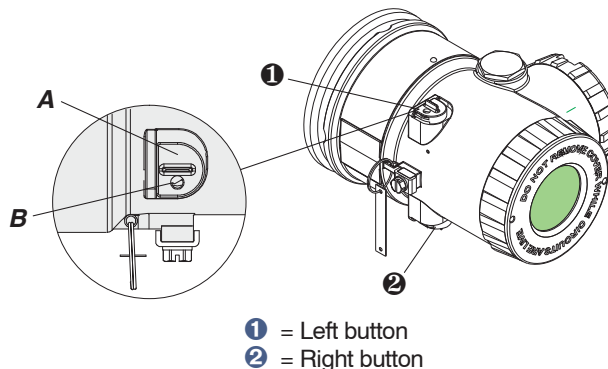

After shifting the key protection cap **A**, insert screw driver or pin ($\varnothing < 3$ mm) into hole **B** and press down to the second pressure point.

Starting from operational view,

- the **2** button switches to details of the operating values
- the **1** button switches to the menu selection, see illustration on the next page.

If no button is pressed within 5 minutes, the display returns automatically to the operational view.

Changing values

Linear adjustment

Is used for example in PV-offset, damping and LCD contrast:

The current value is displayed. With button **2** MORE the value is increased. If the largest value is reached, starts again from beginning with the smallest value. The button has auto repeat.

Stop with button **1** DONE. After that, even queried whether the change should be saved.

Numerical adjustment

Is used for example in measuring range values:

The current value is displayed and the first digit (or sign) is selected. Each time the button **1** CHANGE is pressed the number is counted up, until the desired number is reached. With button **2** NEXT the next number is marked and can be changed, etc.

After that, even queried whether the change should be saved.

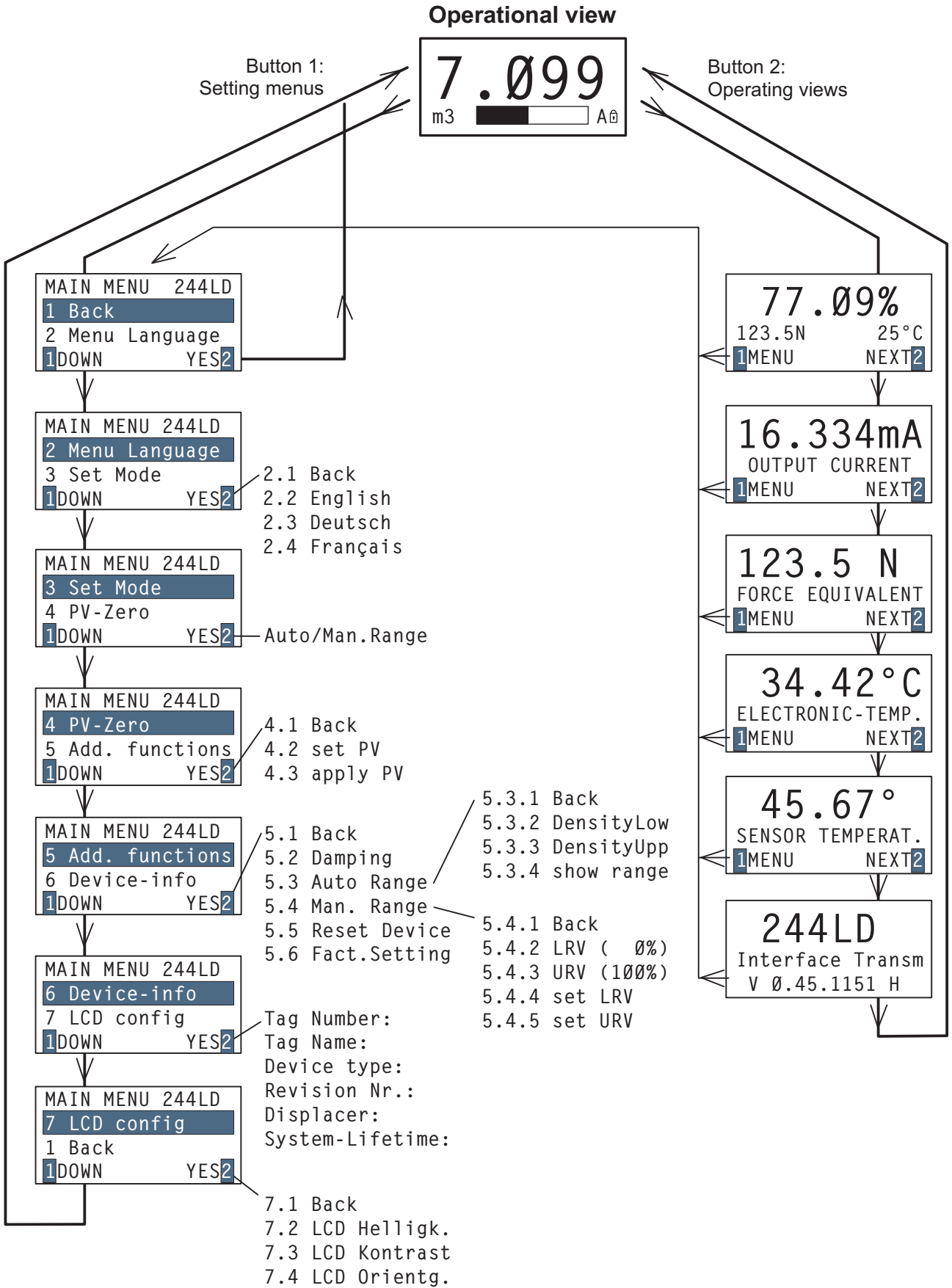

Menu 1: Back

```

MAIN MENU 244LD
1 Back
2 Menu Language
①DOWN YES②
    
```

Back to Operational view.

--> When selecting YES ② it goes **back to the operating view**.

Note: All sub-menus start with a "back" feature that lets you come back to the previous menu. For better clarity omitted in this description.

Menu: Menu language

```

MAIN MENU 244LD
2 Menu Language
3 Set Mode
①DOWN YES②
    
```

--> With YES ② it goes to **language selection**:

```

2 Menu Language
2.1 Back
2.2 English
2.3 Deutsch
2.4 Français
①DOWN YES②
    
```

There are 3 menu languages, standard English, German and French. From the factory, active language is always English.

With ① DOWN the desired language is selected and becomes active with confirming with YES ②. All texts are now displayed in the chosen language. Then it goes automatically **back to the main menu**.

Menu 3: Set mode

```

MAIN MENU 244LD
3 Set Mode
4 PV-Zero
①DOWN YES②
    
```

--> With YES ② it goes to **Autorange- or Manual-** selection.

See also notes on page10

```

3 Set Mode
Auto Mode
Manual Mode
①MODUS OK②
    
```

With ①MODE you switch from Autorange- to Manual Mode. If this is to expect a change in the output value, a message appears.

After confirming with OK ② back to the main menu.

Switching from Manual- to Autorange Mode: Requires reset to factory settings, if manual set data allows no calculations. See menu 5.6.

Menu 4: Setting PV-Offset

```

MAIN MENU 244LD
4 PV-Zero
5 Add. functions
①DOWN YES②
    
```

--> With YES ② it goes to setting **PV-Offset**:

```

4 PV-Zero
4.2 set PV
4.3 apply PV
①DOWN YES②
    
```

--> With YES ② PV-Offset can be set, regardless of the mode Autorange or Manual.

Setting on Linear adjustment in 0.1% increments, see p.10

The expected impact of the change can be seen on the primary variables in the second line.

The resulting automatically calculated PV-offset is displayed on the third line to observe the change and possibly return to the former value.

```

57.0 %
PV=0.100 N
Auto=50.0 %
①READY MORE②
    
```

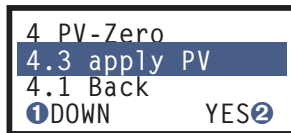

--> With YES 2 the current process value (Level: Displacer not in the medium) is taken over as the physical zero point.

This menu item is only for manual mode and therefore the auto range mode is locked (indicated by a padlock symbol).

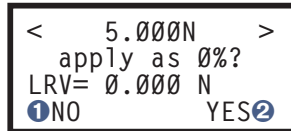

--> By confirmation with YES 2 the current value will be saved as Lower Range Value.

Menu 5: Additional functions



--> With YES 2 it goes to the following sub menus:



--> With YES 2 it goes to **setting the damping**.

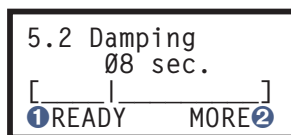

At first the current value is displayed.

The value can now be adjusted with the 2 button in steps of 1 sec. Linear adjustment, see page 10. Then back to the menu.

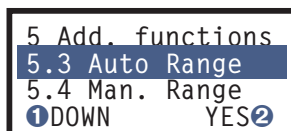

--> With YES 2 it goes to the **Range setting in the Autorange mode**.

In Autorange mode, the densities can be changed and then immediately taken into account in the automatic calculation.

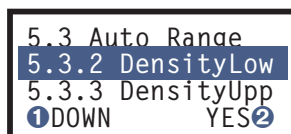

--> With YES 2 to enter the **density of the lower medium**.

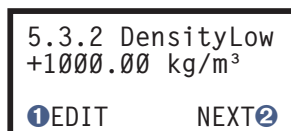

The value is entered using Numerical adjustment, see page 10. Finally, the value must be confirmed and is saved.

If density of lower medium is lighter than the density of upper medium, an error message appears and the value is not stored.

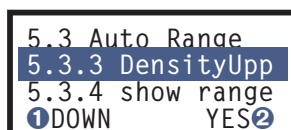

--> With YES 2 to enter the **density of the upper medium**.

(Proceed as with lower density.)

Note: For Level measurement the value is 0.000.

```

5.3 Auto Range
5.3.4 show range
5.3.1 Back
1DOWN      YES2

```

--> With YES **2** the current Measuring range is displayed:

```

Range=100.00 N
LRV= 0.00 N
URV= 100.00 N
BACK2

```

Measuring range
Lower Range Value
Upper Range Value
--> With BACK **2** back to previous menu.

```

5 Add. functions
5.4 Man. Range
5.5 Reset Device
1DOWN      YES2

```

--> With YES **2** it goes to the **Range setting in Manual mode.**

After setting the operating conditions for 0 % (at level: vessel empty) or 100 % (at level: vessel full) each take over the value of the buoyancy force. Or by values input at 0 % and 100 %.

Note: Feature is only available in Manual mode, Autorange mode is locked (padlock icon in the LCD).

```

5.4 Man. Range
5.4.2 LRV ( 0%)
5.4.3 URV (100%)
1DOWN      YES2

```

LRV - take over the Lower Range Value (0 %)

--> With YES **2** the following display appears:

```

< 5.000N >
  apply as 0%?
LRV= 0.000 N
1NO      YES2

```

--> By confirmation with YES **2** the current value will be saved as Lower Range Value.

```

5.4 Man. Range
5.4.3 URV (100%)
5.4.4 set LRV
1DOWN      YES2

```

URV - take over the Upper Range Value (100 %)

(Proceed as with Lower Range Value.)

```

5.4 Man. Range
5.4.4 set LRV
5.4.5 set URV
1DOWN      YES2

```

LRV - enter the Lower Range Value (0 %)

--> With YES **2** the following display appears:

```

5.4.4 set LRV
+010.000 %
min= 000.000 %
1EDIT      NEXT2

```

The value is entered using Numerical adjustment, see page 10.
In the third line, the minimum value is displayed.
Finally, the value must be confirmed and is then stored as Lower Range Value.

```

5.4 Man. Range
5.4.5 set URV
5.4.1 Back
1DOWN      YES2

```

URV - enter the Upper Range Value (100 %)

(Proceed as with Lower Range Value.)

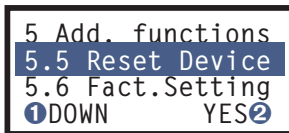

--> With YES 2 it goes to function selection.
After a further confirmation the reset of electronics is running.
Same effect as Power-on.

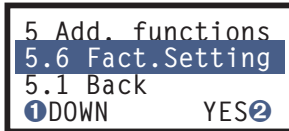

--> With YES 2 it goes to function selection.
WARNING: According to a further confirmation, **all custom settings are reset to the factory-defined state** and will be lost.

Menu 6: Device informations



--> YES 2 displays the data stored in the transmitter, such as
Tag Number
Tag Name
Device type
Revision Nr
Displacer data
System-Lifetime

Menu 7: LCD configuration



--> With YES 2 it goes to **settings for the LCD**:

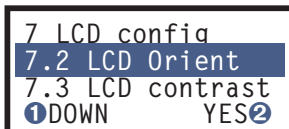

--> With YES 2 it goes to selection of **LCD orientation**:

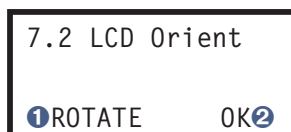

--> With 1 ROTATE is the text "on the feet".

--> With confirming with OK 2 it goes back to the menu.

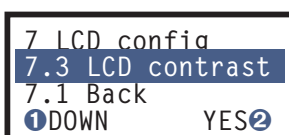
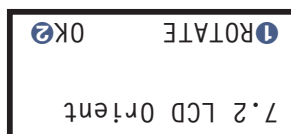

--> With YES 2 the LCD contrast is adjusted.
Linear adjustment, see page 10.

9 DIMENSIONING OF DISPLACER

CALCULATING WEIGHT FORCES (also see VDI/VDE-Guideline 3519, sheet 1)

Displacer length = measuring range

Measurement type	Weight forces		0 %	100 %
	Lower range value = 0 % output signal	Upper range value = 100 % output signal		
Liquid level (ρ_2 = negligible)	$F_0 = F_G$	$F_{100} = F_G - V \cdot g \cdot \rho_1$		
Interface (ρ_2 = not negligible)	$F_0 = F_G - V \cdot g \cdot \rho_2$			
Density (ρ_2 = min. density, ρ_1 = max. density)				

Displacer length > measuring range
(without elevation)

Measurement type	Weight forces		0 %	100 %
	Lower range value = 0 % output signal	Upper range value = 100 % output signal		
Liquid level (ρ_2 = negligible)	$F_0 = F_G$	$F_{100} = F_G - V \cdot g \cdot \rho_1 \cdot \frac{h_b}{L}$		
Interface (ρ_2 = not negligible)	$F_0 = F_G - V \cdot g \cdot \rho_2$	$F_{100} = F_G - V \cdot g \cdot (\rho_1 \cdot \frac{h_b}{L} + \rho_2 \cdot \frac{L - h_b}{L})$		

Displacer length > measuring range
(with elevation)

Measurement type	Weight forces		0 %	100 %
	Lower range value = 0 % output signal	Upper range value = 100 % output signal		
Liquid level (ρ_2 = negligible)	$F_0 = F_G - V \cdot g \cdot \rho_1 \cdot \frac{h_0}{L}$	$F_{100} = F_G - V \cdot g \cdot \rho_1 \cdot \frac{h_0 + h_b}{L}$		
Interface (ρ_2 = not negligible)	$F_0 = F_G - V \cdot g \cdot (\rho_1 \cdot \frac{h_0}{L} + \rho_2 \cdot \frac{L - h_0}{L})$	$F_{100} = F_G - V \cdot g \cdot (\rho_1 \cdot \frac{h_0 + h_b}{L} + \rho_2 \cdot \frac{L - h_b - h_0}{L})$		

- F_G [N] Weight force of displacer in atmosphere
- F_0 [N] Weight force action on suspension point of displacer at lower range value
- F_{100} [N] Weight force action on suspension point of displacer at upper range value
- F_A [N] Buoyancy force of displacer ($F_A = F_0 - F_{100}$)
- V [m³] Displacer volume (specified on data label in cm³)

- ρ_1 [kg/m³] Liquid density
- ρ_2 [kg/m³] Density of gas or lighter liquid
- g [m/s²] Local acceleration due to gravity (e.g. 9.807 m/s²)
- L [m] Displacer length
- h_0 [m] Lower range value
- h_b [m] Measuring span

Attention: 1 kg generates a force of 9.807 N

1) ρ_2 is negligible if ρ_2 = gas at atmospheric pressure or with ratio $\rho_2 : \rho_1$ less than 0.5 %.

Graph for determining displacer diameter

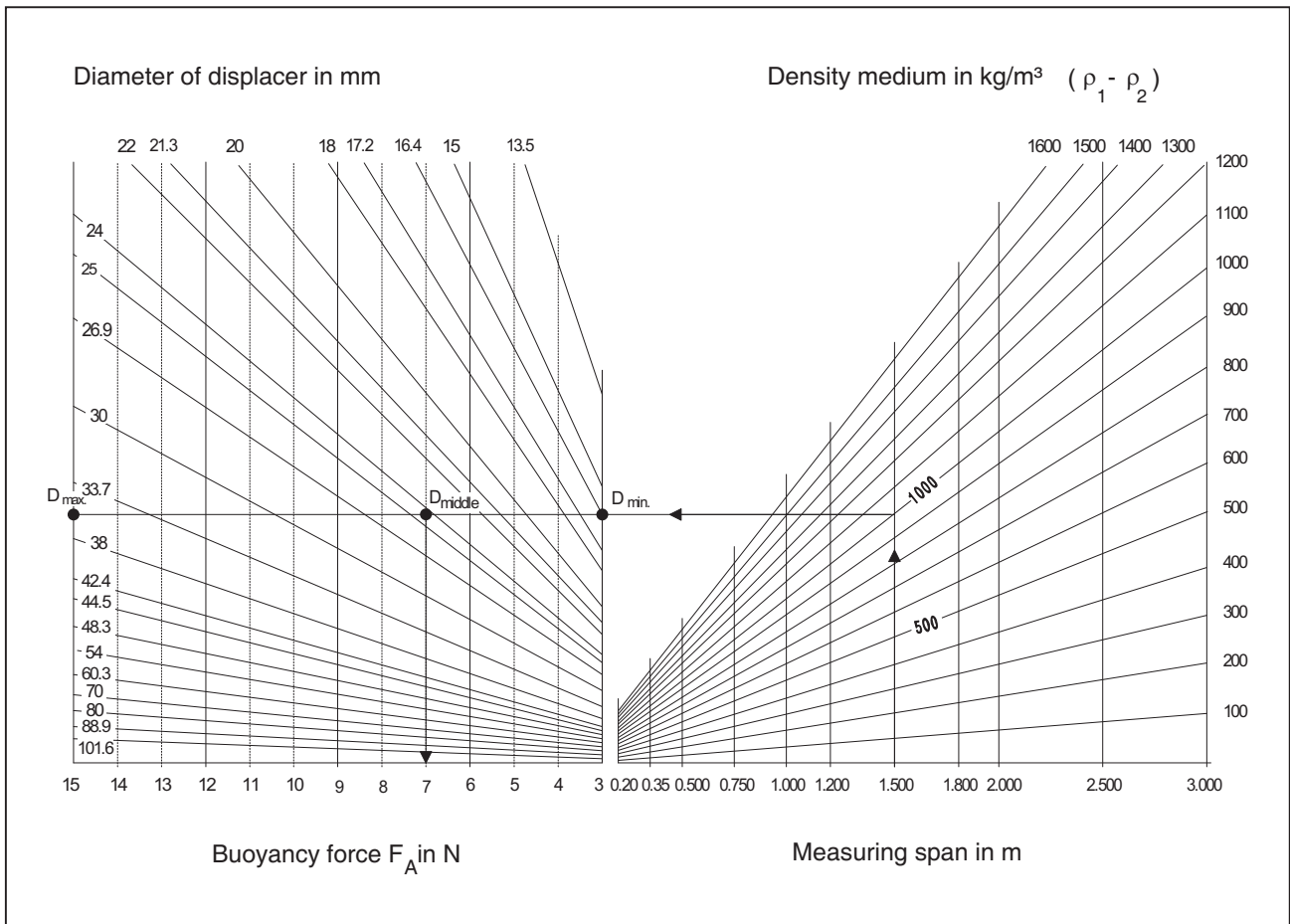

Measuring span

The transmitter is designed for a buoyancy force measuring span of minimum 2 up to maximum 20 N.

Weight force

The maximum weight of the displacer F_G max. is 25 N for level measurements. For density or interface measurements, the displacer must be dimensioned so that after deducting F_A of the lighter process media, the remaining force F_0 does not exceed 25 N.

Determining displacer diameters

For optimum use of the transmitter, the displacer should be dimensioned so that the greatest possible buoyancy force is generated over the measuring range. On the other hand, the maximum possible diameter of the displacer must be taken into consideration.

In the above graph the displacer diameter can easily be estimated dependent on the measuring span and the buoyancy force.

The following equation can be used to exactly dimension the displacer:

$$D = 1000 \sqrt{\frac{4 F_A}{\pi g (\rho_1 - \rho_2) L}} \quad [\text{mm}]$$

- D = Outside diameter of displacer in mm
- F_A = Buoyancy force of displacer in N
- g = Acceleration due to gravity (9.807 m/s²)
- ρ_1 = Density of heavier liquid in kg/m³
- ρ_2 = Density of gas or lighter liquid in kg/m³
- L = Measuring span in m

Example:

- Measuring span: 1.500 m
- ρ_1 = 1000 kg/m³
- ρ_2 = negligible

10 Measuring principle

(see VDI/VDE Guideline 3519, sheet 1)
 Any body immersed into a liquid is subject to Archimedian buoyancy force which depends on the liquid density. This is exploited to determine liquid level, density and interface level by suspending a displacer with constant cylindric

shape into a liquid.
 Changes in buoyancy forces are proportional to liquid level changes and are converted to a measuring signal.
 The displacer is fully immersed for density and interface level detection.

The following applies in general to the buoyancy force acting on the displacer:

$$F_A = V_x \cdot \rho_1 \cdot g + (V - V_x) \cdot \rho_2 \cdot g$$

- F_A Buoyancy force
- V Volume of displacer
- V_x Volume of medium displaced by measuring body with density ρ_1
- ρ_1 Average density of heavier medium
- ρ_2 Average density of lighter medium
- g Local acceleration due to gravity
- F_G Displacer body weight force

The force acting on the transmitter is inversely proportional to liquid level changes.

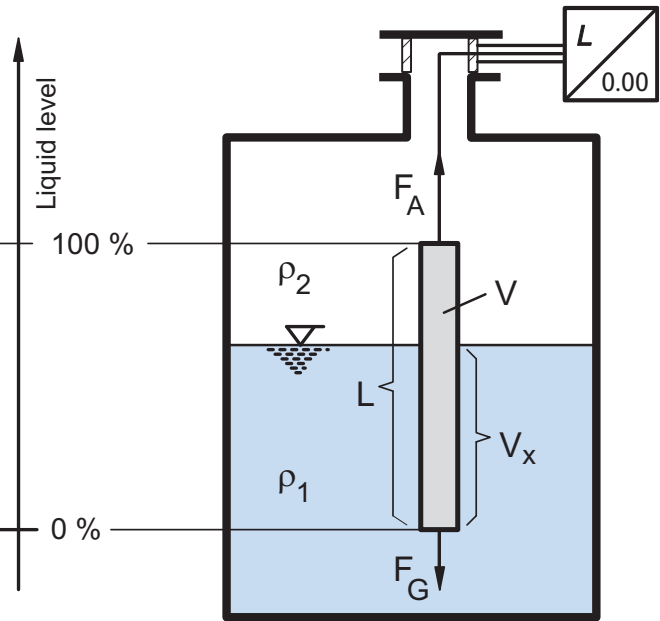
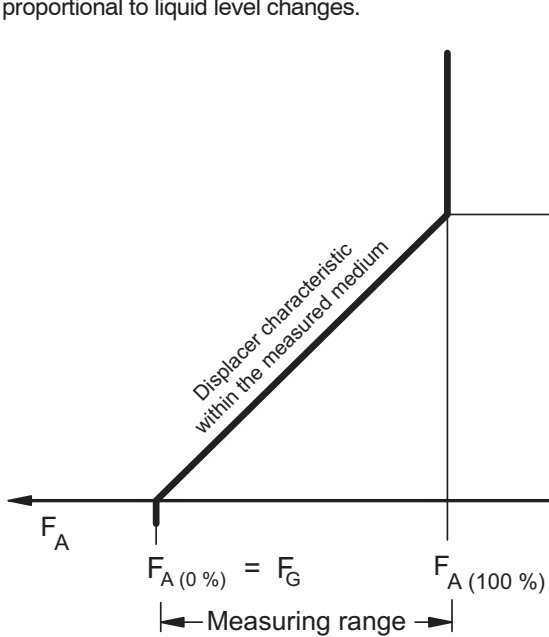

10.1 Block diagram with HART communication

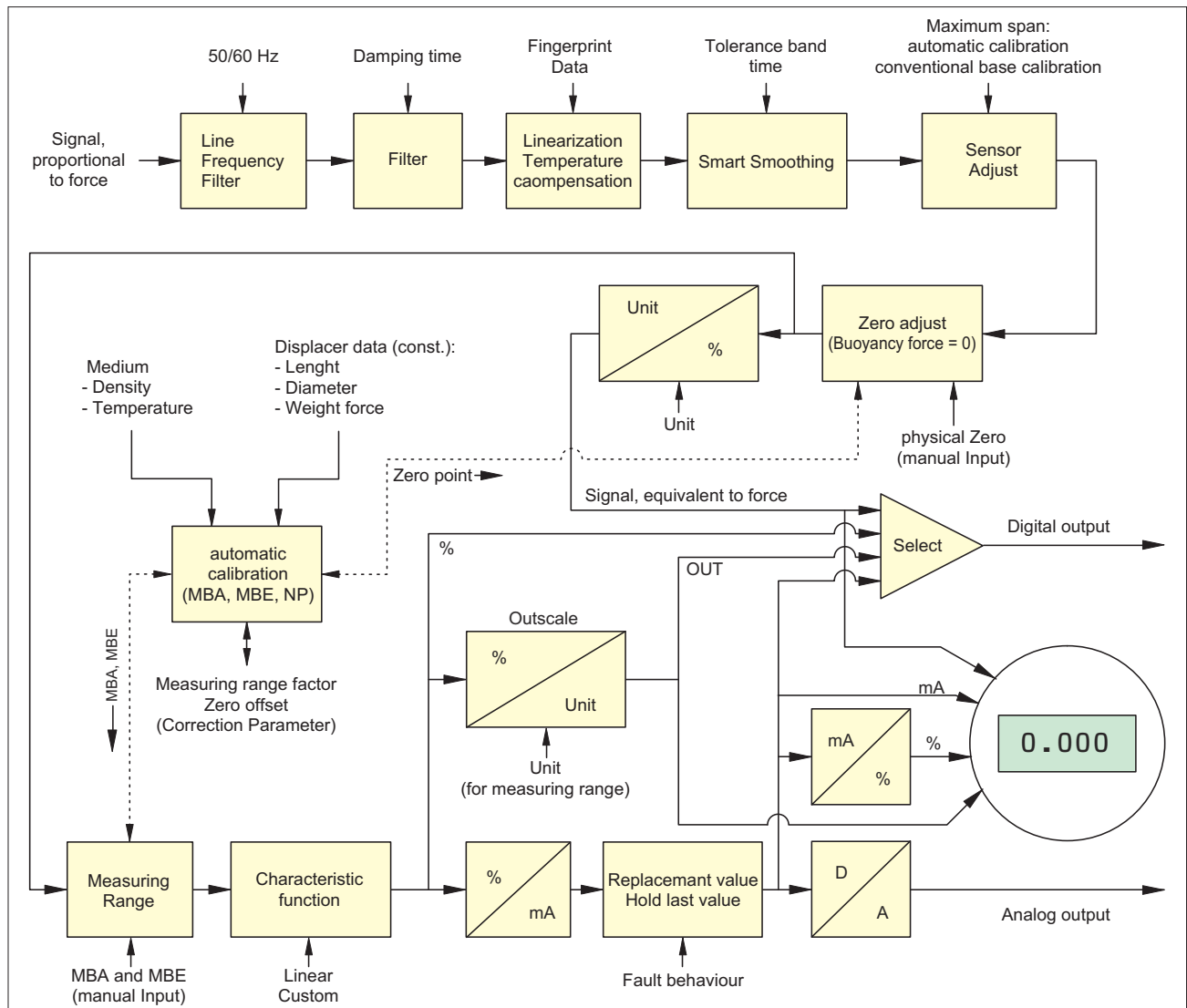

10.2 Explanations to Block diagrams

Sensor

The force sensor is a Wheatstone bridge of four metal strain gauge elements and a Ni100 resistor for temperature measurement.

Line Frequency Suppression Filter

There is the selection to filter the noise signal 50 Hz or 60 Hz.

Linearization and Temperature compensation of Sensor characteristic

The sensor signal is linearized and temperature-compensated by the included sensor temperature. Linearization takes place via the so-called fingerprint data, which are determined during the production for each sensor. In factory the fingerprint data are loaded into the amplifier.

Smart Smoothing

In factory the Smart Smoothing Band is set to 2 % of sensor range. The Integration Time of the average value is set to 10 sec.

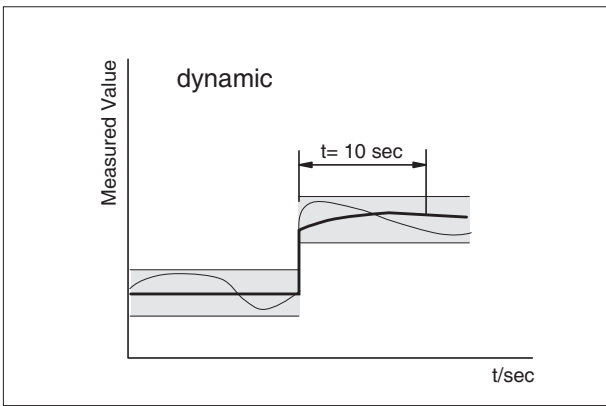
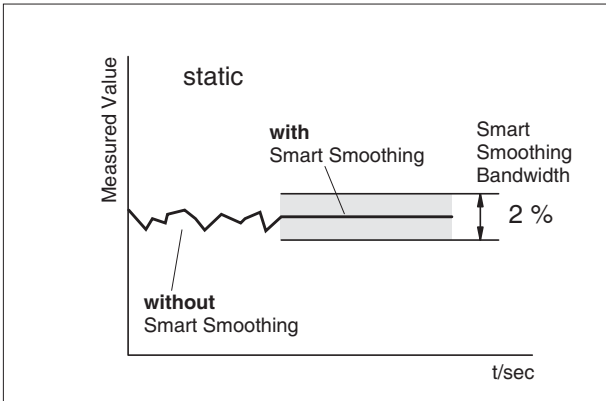

Sensor Adjustment

Zero and span of force sensor are adjusted in factory. It is possible to calibrate Zero (situation alignment) with the external keys.

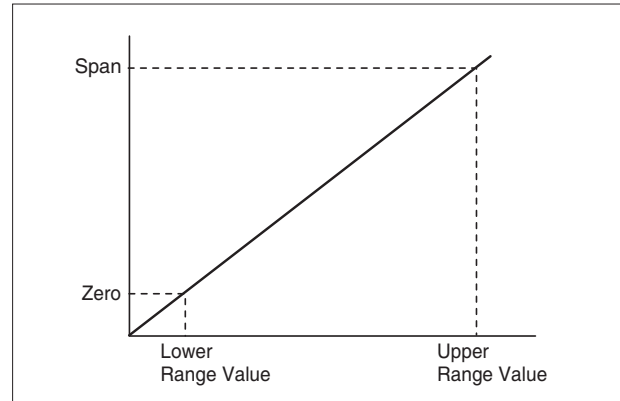

Transfer function / Characteristic

The characteristics are available as linear and customized. With "customized" there are 32 x/y- values available. Standard with Level is "linear".

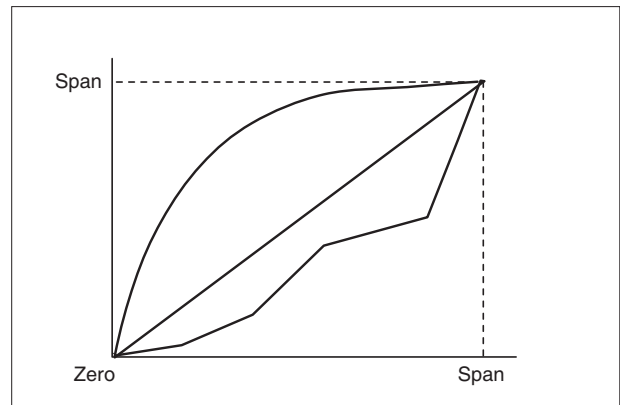

Measured Value Setting

The user can define measured value and unit.

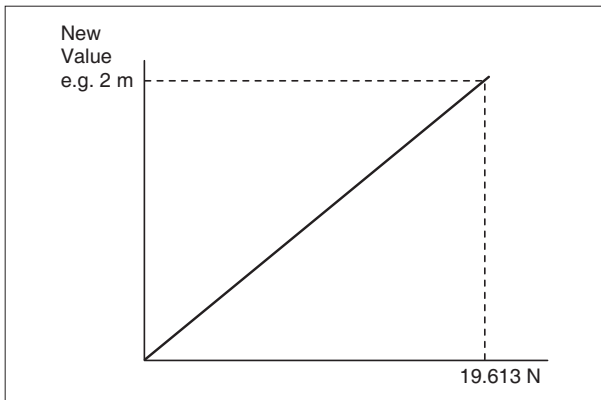
**Setting of Output value**

The output value is the measured value between Lower Range Value and Upper Range Value. Value and unit are freely selectable. The replacement value affects the output.

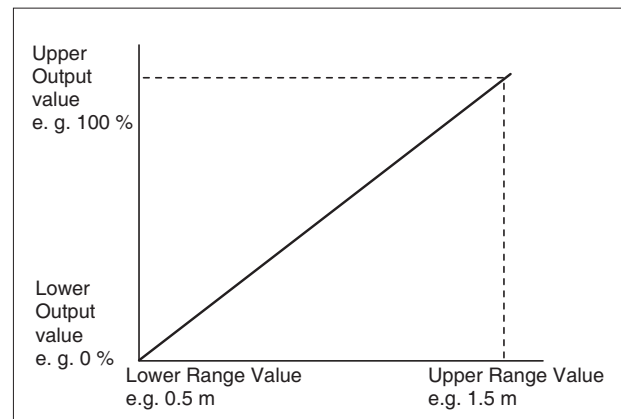
**Setting of Range**

The measuring range is the range between Lower Range Value and Upper Range Value. Lower Range Value is the weight of the displacer. Lower Range Value without elevation is 0. With elevation, the value of elevation has to be entered.

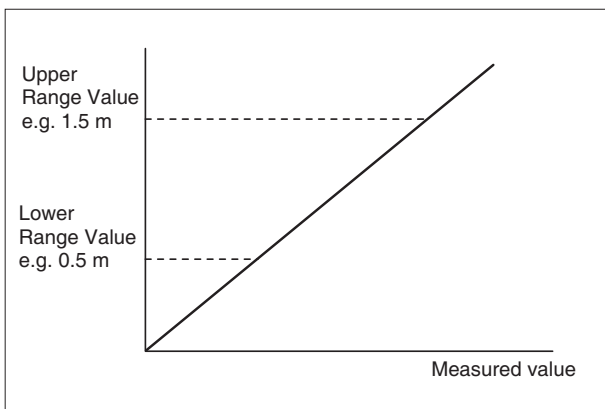
**Replacement / Substitute Value (HART only)**

In case of error output holds last value or gives a configurable Replacement value.

If the error does not exist any longer, then "last value" and/or replacement value is taken back (automatic or manually).

Multi-drop (HART only)

With FDT-DTM or a Hand Held Terminal it is possible to switch

- HART-Amplifier between "analog" and "Multi-drop"
- FoxCom-Amplifier between "analog" and "digital".

With HART-mode "Multi-drop" the output has a digital signal, the measured value is modulated to a 4 mA DC signal.

FDT-DTM Software enables to simulate the measured value and to write output values directly to the output.

Filter

The output signal is damped. Damping time ist setable from 0 to 32 sec.

11 SUPPLY OF TRANSMITTER

11.1 General

Depending on the transmitter application varying demands are made on the supply. The different operating modes are explained in the following chapters. The wire diagrams are shown in the following figures.

The power supply units for different applications (direct / via power supply unit of transmitters, HART / without communication, intrinsically / not intrinsically) are listed in the following table.

All listed supply devices are available for intrinsically-safe and/or non-intrinsically-safe application.

Application and associated supply

Application	Supply (recommended)
without communication	direct, MT228
HART	direct, MT228

11.2 Overview of application types

Supply via power supply unit (Fig. 1)

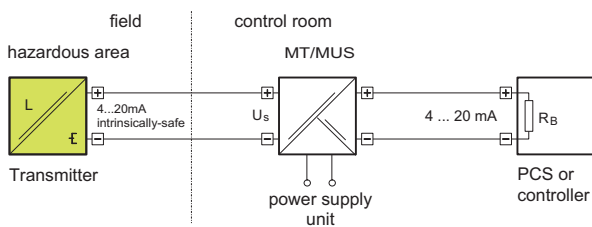

Direct supply (Fig. 2)

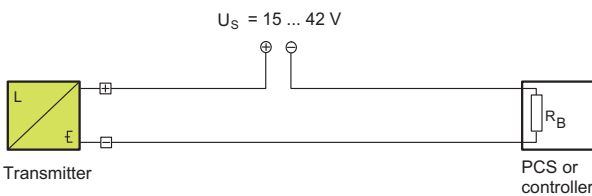

Supply via power supply unit with communication (Fig. 3)

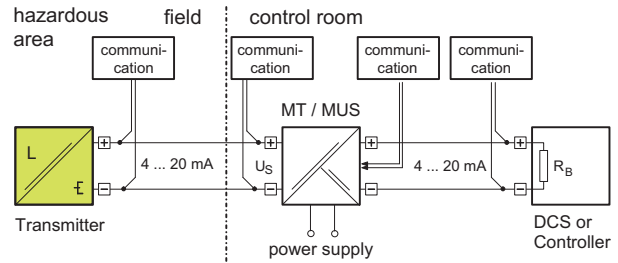

Direct supply with communication (Fig. 4)

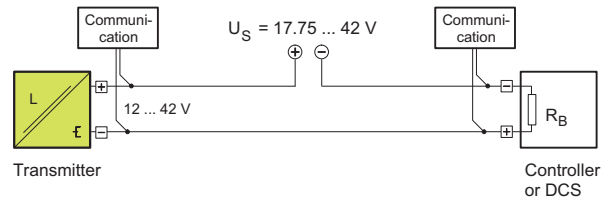

11.2.1 Supply via power supply unit

This supply is recommend for normal use. Interferences are prevented due galvanic separation of measurement loop, load and power supply in the power supply unit (see fig. 1)

11.2.2 Direct supply

This most simple version can be recommended only for single galvanically separated supply or measurement loops (see fig. 2)

The max. load impedance is calculated per:

$$R_{Bmax} = (U_{max} - 12 V) / I_{max}$$

U_{max} : max. permitted voltage (acc. to product specifications), depends on type of transmitter and explosion protection

I_{max} : 12 mA for transmitter in FOXCOM digital mode, 23 mA for all other transmitters (HART and FOX-COM)

Permissible load depending on supply voltage.

Example of a non intrinsically safe 140 series HART transmitter (Fig. 6)

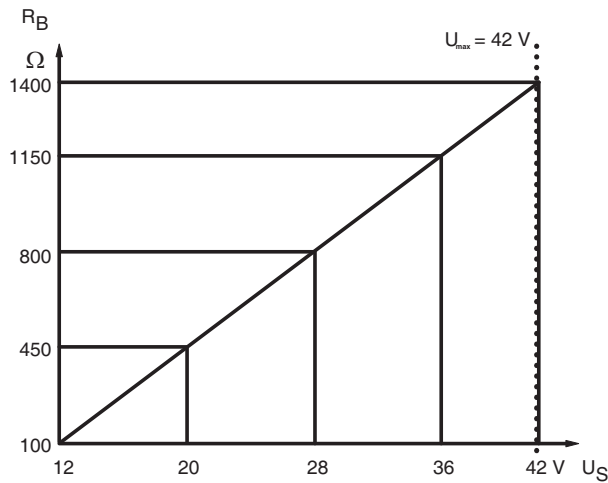
**11.2.3 Communication**

In contrast to conventional operating mode in the two-wire loop **a minimal load for all communication modes** has to be available. If this load is selected too low, the communication is short-circuited.

(FOXBORO power supply units capable for communication MT228 already have respective loads).

Additionally, the line lengths have to be limited to the max. permitted values for the respective communication

Standard values

Communication	HART		
Min. load	250 Ω		
Max. capacity of line	< 200 nF		
Max. length of line	~ 3300 m		

The respective wiring diagram is shown in Figure 3.

Figure 4 shows the respective wiring diagram without power supply unit for galvanically separated loops. The operating tool - handterminal, PC with FDT-DTM software and modem - can be connected to the labeled positions. Depending on the application the regulations for explosion protection have to be observed also for the operating tools!

11.2.4 Intrinsically-safe application

For intrinsically-safe application generally the use of a respective power supply unit is recommended. Wiring should be done as per respective national and international standards and regulations - as described in "Supply via power supply unit". If communication is required also, the guidelines of chapter "Communication" have to be observed. In addition, the application of the operating tools and their permitted limit values are to be observed.

12 Error messages on LCD display and on DTM screen

Err.Nr.	Message Text	Instrument State	Possible cause	Action
0	INT CALIB FAILED INT.CALIB. INVAL*	Warning message Device is not in safe mode	This is a reaction from the error "FINGER PRINT ERR"	see "FINGER PRINT ERR"
3	SENSOR INVALID	Critical error. $I_{out}= 24$ mA. No level measurement, HART-Communication available Monitor function via service port avail.	1. wrong sensor replace procedure 2. Sensor failed	1. Write finger print data for the new sensor bevor replace the sensor 2. Check sensor connections or replace sensor
4	OUT OF SENS LIMIT	Warning message Device is not in safe mode	Sensor value is out of range	1. Check displacer weight 2. Check sensor calibration
5	SENS TEMP LIMIT	Warning for Sensor Temperatue between -50°C ... 60°C or 120°C ... 150°C. Critical Error for Temperature < -60°C or > 150°C. $I_{out}= 24$ mA, HART-Communication and Monitor (service port) are available	1. Temperatur range -60 °C to -50 °C or 120 °C to 150 °C out of limit (only warning). 2. Temperatur is lower -60 °C or greater +150 °C (critical error)	Check/change the process temperatur in case of critical error.
6	ELEC TEMP LIMIT	Warning for Electronic Temperature between -40°C ... -60°C or 89°C ... 105°C. Device is not in safe mode.	Electronic Temperature out of limits. Temperature is between -40°C ... -60°C or 89°C ... 105°C.	Ambient or process temperature is to low/high
7	MEAS RANGE INVAL	Warning message Device is not in safe mode	Not implemented in Levelstar	No
8	PV OUT OF LIMIT	Warning message Device is not in safe mode	PV out of limits (<-3,0 % or >110 %)	1. check displacer weight 2. check measure range and zero point
9	VAR OUT OF LIMIT OUT OF LIMITS*	See "TEXTS ARE WRONG" or "DIAGNOSTIC ERROR"	This error message is a reaction of the "TEXTS ARE WRONG" and "DIAGNOSTIC ERROR"	See "TEXTS ARE WRONG" or "DIAGNOSTIC ERROR"
10	ANALOG OUT SATUR CURR OUT OF LIMT*	Warning message for I_{out} out of limits. Device is not in safe mode	The output current is out of limit: 3,8 mA (-1,25 %) and 20,5 mA (103,123 %)	Check measure range
11	CURRENT FIXED	Warning message Device is not in safe mode	Output current is fixed (for example current calibration or critical error)	No
12	MORE STAT AVAIL.	Critical error. $I_{out}= 24$ mA. No level measurement, HART-Communication available Monitor function via service port avail.	Status bit for extended status	No
13	COLD START	Warning message Device is not in safe mode	Shows, that the device was restarted during the safety mode	No
14	CONFIG. CHANGED	Warning message Device is not in safe mode	Configuration has been changed	The message can be reset with DTM or HHT with "reset status" function
15	HARDWARE ERROR	Critical error. $I_{out}= 24$ mA. No level measurement, HART-Communication available Monitor function via service port avail.	This error message is a reaction of the error messages: 21 - 33	
16	OUT OF MEAS RANG	Warning message Device is not in safe mode	PV is out of measure range	check measure range
17	FINGER PRINT ERR	Warning message Device is not in safe mode	The raw value is > 15 % or < -115 %	1. check displacer weight 2. check finger print data
18	LANG TEXT ERROR TEXTS ARE WRONG*	Warning message Device is not in safe mode	internal problem with the language texts	try to download the third language via DTM
19	DIAG INCOMPLETE DIAGNOSTIC ERROR*	Warning message (Critical error. $I_{out}= 24$ mA in safety mode) HART-Communication available Monitor function via service port avail.	Diagnostic function(s) was not executed.	Not all calibrations was executed
20	DISPL. TOO LIGHT	Warning message (Critical error. $I_{out}= 24$ mA in safety mode) HART-Communication available Monitor function via service port avail.	Sensor value is over the calibrated value > 110 %	1. check displacer 2. check sensor calibration
21	NO FACT SETTINGS	Warning message Device is not in safe mode	Not all factory calibrations were executed	Make all calibrations
22	LOOP CURRENT ERR ILL LOOP CURRENT*	Critical error. $I_{out}= 24$ mA, if the device power is OK. Otherwise 3,6 mA. No level measurement, HART-Communication and Monitor (service port) are available.	1. reason: the power is to low to generate a required current (error value on LCD = 1111.11) 2. reason: the measured and digital current has a deviation of 1,0 %	1. check the power 2. change electronic
23	SENS.CURRENT ERR	Critical error. $I_{out}= 24$ mA. No level measurement, HART-Communication available Monitor function via service port avail.	Sensor current failure	1. change sensor 2. change electronic
24	SENS REF ERROR	Critical error. $I_{out}= 24$ mA. No level measurement, HART-Communication available Monitor function via service port avail.	Sensor-Reference voltage failure	change electronic
25	TEMP SENS FAILED TEMP.-SENS INVAL*	Critical error. $I_{out}= 24$ mA. No level measurement, HART-Communication available Monitor function via service port avail.	Temperature measurement failure	change electronic or sensor

26	EL TEMP SENS ERR	Critical error. $I_{out}= 24$ mA. No level measurement, HART-Communication available Monitor function via service port avail.	1. Temperature is < -60 °C or > 105 °C 2. Temperature change is faster 1 °C / sec.	change electronic
27	WATCHDOG ERROR	Critical error. $I_{out}= 24$ mA. No level measurement, HART-Communication available Monitor function via service port avail.	Watchdog has detected a failure	Check firmware version present Check for available Firmware update if up to date Exchange electronic module
28	ADC GAIN ERROR	Critical error. $I_{out}= 24$ mA. No level measurement, HART-Communication available Monitor function via service port avail.	Electronic defect or an inconsistency in calibration	change electronic or make a new electronic calibration
29	INT REF ERROR 100 OHM ERROR*	Critical error. $I_{out}= 24$ mA. No level measurement, HART-Communication available Monitor function via service port avail.	Electronic defect	change electronic
30	ADC BIT ERROR	Critical error. $I_{out}= 24$ mA. No level measurement, HART-Communication available Monitor function via service port avail.	Electronic defect	change electronic
31	SYS OFFSET ERROR	Critical error. $I_{out}= 24$ mA. No level measurement, HART-Communication available Monitor function via service port avail.	1. Electronic defect 2. Sensor recalibration (Sensor Trimm) required after the electronic change	1. change electronic 2. do sensor calibration
32	HART MODEM FAIL HART MODEM FIRMW*	Warning message	1. No HART modem firmware downloaded 2. HART-modem chip is defect	1. download a new modem firmware 2. change the electronic
33	PWR SPPLY INSUFF	Critical error. $I_{out}= 24$ mA. No level measurement, No HART-Communication Monitor function via service port avail.		check power supply
	* = Firmware version < 8.XXX			

Invensys Systems, Inc.
38 Neponset Street
Foxboro, MA 02035
United States of America

schneider-electric.com

Global Customer Support
Toll free: 1-866-746-6477
Global: 1-508-549-2424
Website: <http://support.ips.invensys.com>

Copyright 2010-2016 Invensys Systems, Inc.
All rights reserved.

Invensys, Foxboro, and I/A Series are trademarks
of Invensys Limited, its subsidiaries, and affiliates.
All other trademarks are the property of their
respective owners.

DOKT 556 588 241
FD-MI-L-004-EN